

- BF442 1-2-Both-OFF
- BF442A 1-2-Both-OFF with AFD

Battery Selector Switch

Compact Size 3 Way Switch for 2 or more batteries

- Unique ergonomic and aesthetic knob design
- Smallest battery switch with AFD (Alternator Field Disconnect) feature in market (BF442A)
- Robust Glass Fiber reinforced Nylon enclosure
- Removable windows for unobstructed wiring
- Surface or panel mount options provides flexibility when installing
- Meets ISO8846 Ignition Protection, suitable for installation in engine room

Product Specifications

- Cranking Rating(10 Secs) | DC 1000A
- Intermittent Rating (5 mins) | DC 300A
- Continuous Rating | DC 200A
- Voltage Rating | DC 48V
- Terminal Studs | M8 (5/16 ")
- Notes | CE ISO8846/SAE J1171 Ignition Protected

Installation Instructions:

1. Disconnect positive terminal from battery.
2. Mount the battery switch onto desired surface (surface mount) or panel (panel mount).

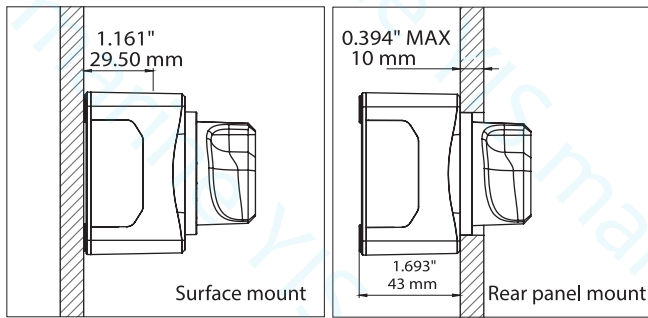

3. Connect terminal 1 to battery 1 positive, connect terminal 2 to battery 2 positive, and connect the COM terminal to alternator and/or loads.
4. (BF442A Only) Cut the field wire from the alternator to the voltage regulator and connect one end to F1, and the other end to F2.

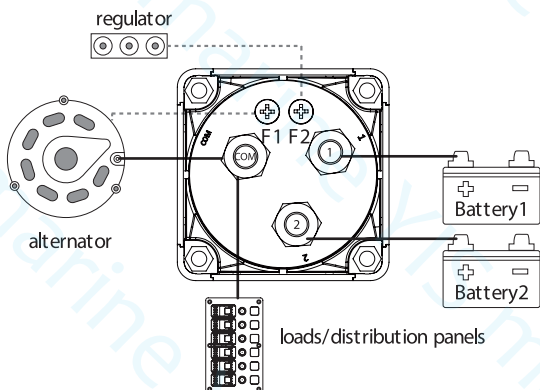

5. Use 4/0 AWG cables on all terminals to meet current rating. Make sure nuts and locker washer are properly attached with enough torque.
6. Remove proper side-plate for cable output; do not remove side-plate facing upward as water may get in from the top.

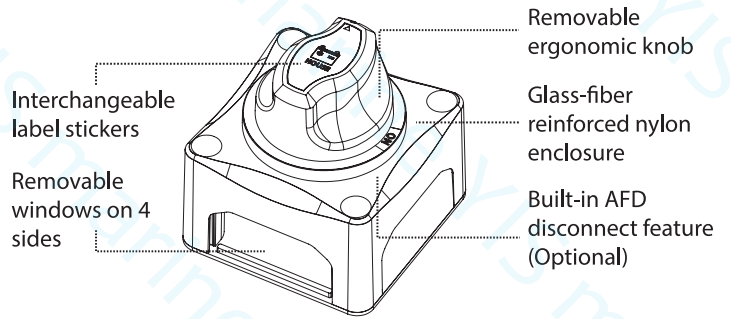

AFD (Alternator Field Disconnect):

AFD is to protect the alternator diodes if the battery is accidentally turned OFF. Battery switch with AFD will cut off alternator output before cut off the main circuit it controls.

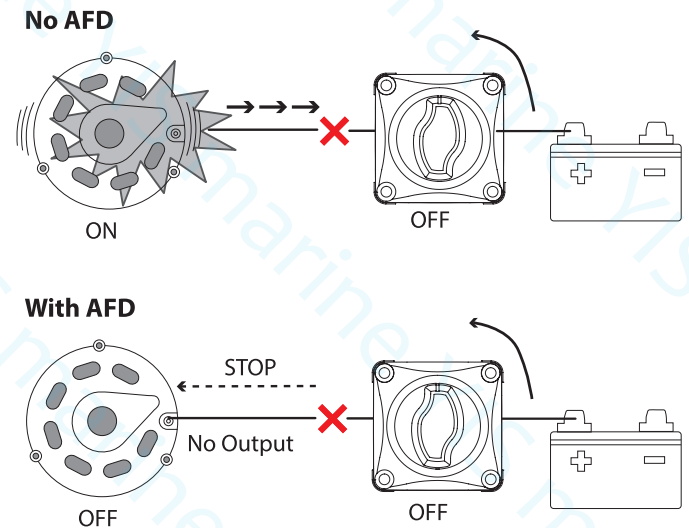

Note:

1. To remove knob, turn the battery switch off and then turn 30° counterclockwise and pull out.

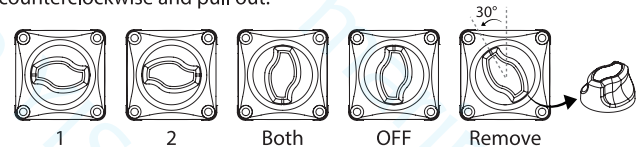

2. Turn off all equipment before turning the battery switch OFF.
3. Do not turn battery switch to OFF while engine is running.

